

Subject: Computer
networks

Topic: Switching

LISNA THOMAS

ACADEMIC YEAR:2020-21

Switching Techniques

In large networks there might be multiple paths linking sender and receiver. Information may be switched as it travels through various communication channels. There are three typical switching techniques available for digital traffic.

- Circuit Switching
- Message Switching
- Packet Switching

Circuit Switching

- **Circuit switching** is a technique that directly connects the sender and the receiver in an unbroken path.
- Telephone switching equipment, for example, establishes a path that connects the caller's telephone to the receiver's telephone by making a physical connection.
- In this type of switching technique, once a connection is established, a dedicated path exists between both ends until the connection is terminated.
- Routing decisions must be made when the circuit is first established, but decisions cannot be made after that time.

Circuit Switching

- **Circuit switching** networks operate almost the same way as the telephone system works.
- A complete end-to-end path must exist before communication can take place.
- The computer initiating the data transfer must ask for a connection to the destination.
- Before the establishment of the connection, the destination must send the acknowledge to the source node to indicate that it is ready and willing to send/receive data.

Circuit switching

Advantages:

- The communication channel (once established) is dedicated.

Disadvantages:

- Possible long wait to establish a connection, (10 seconds, more on long- distance or international calls.) during which no data can be transmitted.
- More expensive than any other switching techniques, because a dedicated path is required for each connection.
- Inefficient use of the communication channel, because the channel is not used when the connected systems are not using it.

Message Switching

- In message switching there is no need to establish a dedicated path between two stations.
- When a station sends a message, the destination address is appended to the message.
- The message is then transmitted through the network, in its entirety, from node to node.
- Each node receives the entire message, stores it in its entirety on disk, and then transmits the message to the next node.
- This type of network is called a store-and-forward network.

Message Switching

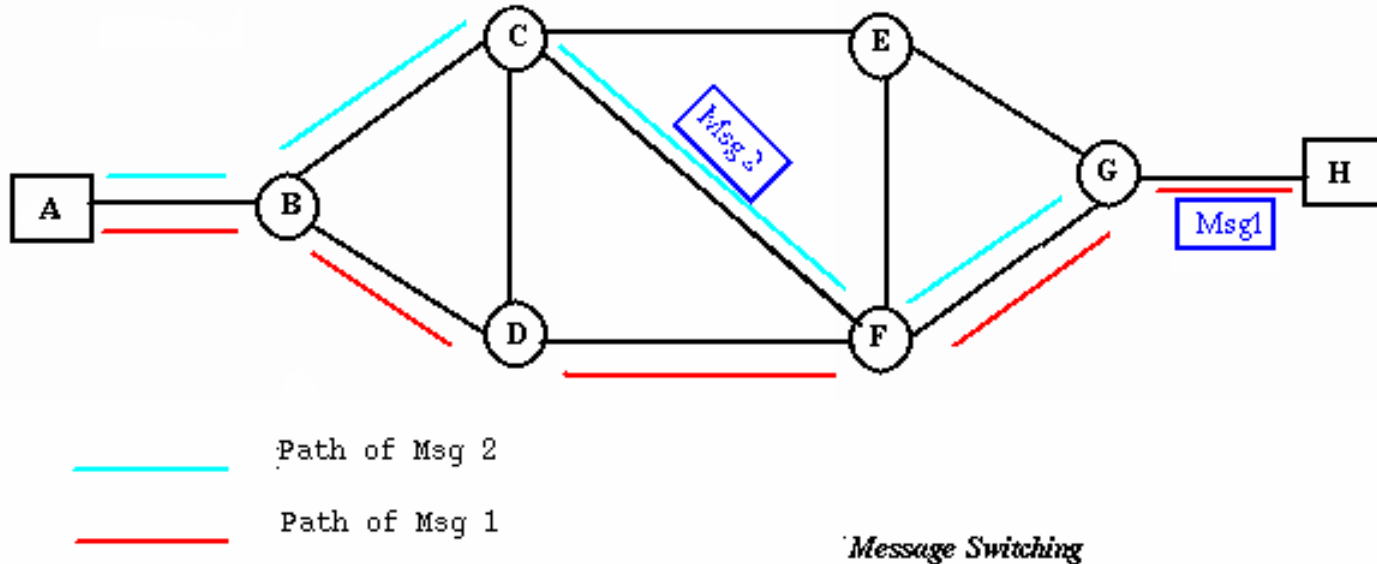

A message-switching node is typically a general-purpose computer. The device needs sufficient secondary-storage capacity to store the incoming messages, which could be long. A time delay is introduced using this type of scheme due to store- and-forward time, plus the time required to find the next node in the transmission path.

Message Switching

Advantages:

- Channel efficiency can be greater compared to circuit-switched systems, because more devices are sharing the channel.
- Traffic congestion can be reduced, because messages may be temporarily stored in route.
- Message priorities can be established due to store-and-forward technique.
- Message broadcasting can be achieved with the use of broadcast address appended in the message.

Message Switching

Disadvantages

- Message switching is not compatible with interactive applications.
- Store-and-forward devices are expensive, because they must have large disks to hold potentially long messages.

Packet Switching

- *Packet switching* can be seen as a solution that tries to combine the advantages of message and circuit switching and to minimize the disadvantages of both.
- There are two methods of packet switching: Datagram and virtual circuit.

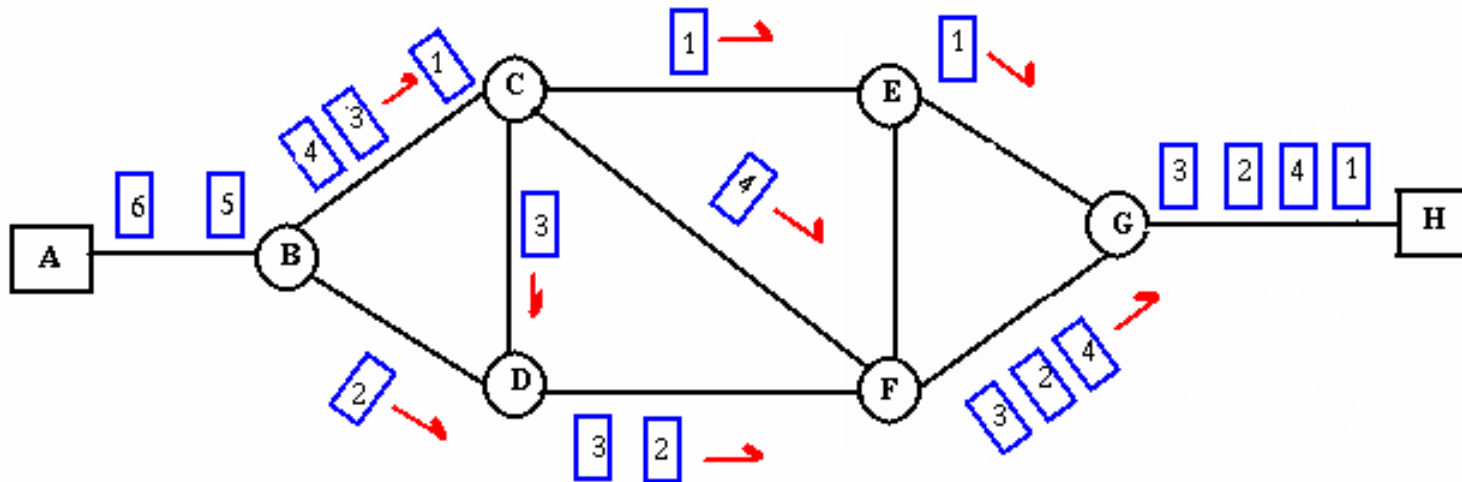

Packet Switching

Packet Switching

- In both packet switching methods, a message is broken into small parts, called packets.
- Each packet is tagged with appropriate source and destination addresses.
- Since packets have a strictly defined maximum length, they can be stored in main memory instead of disk, therefore access delay and cost are minimized.
- Also the transmission speeds, between nodes, are optimized.
- With current technology, packets are generally accepted onto the network on a first-come, first-served basis. If the network becomes overloaded, packets are delayed or discarded ("dropped").

Packet size

- The size of the packet can be:
 - 180 bits for the Datakit® virtual circuit switch designed by Bell Labs for communications and business applications.
 - 1,024 or 2,048 bits for the 1PSS® switch, also designed by Bell Labs for public data networking.
 - 53 bytes for ATM switching, such as Lucent Technologies' packet switches.

Packet switching

- In packet switching, the analog signal from your phone is converted into a digital data stream. That series of digital bits is then divided into relatively tiny clusters of bits, called packets. Each packet has at its beginning the digital address -- a long number -- to which it is being sent. The system blasts out all those tiny packets, as fast as it can, and they travel across the nation's digital backbone systems to their destination: the telephone, or rather the telephone system, of the person you're calling.
- They do not necessarily travel together; they do not travel sequentially. They don't even all travel via the same route. But eventually they arrive at the right point -- that digital address added to the front of each string of digital data -- and at their destination are reassembled into the correct order, then converted to analog form, so your friend can understand what you're saying.

Packet Switching: Datagram

- Datagram packet switching is similar to message switching in that each packet is a self-contained unit with complete addressing information attached.
- This allows packets to take a variety of possible paths through the network.
- So the packets, each with the same destination address, do not follow the same route, and they may arrive out of sequence at the exit point node (or the destination).
- Reordering is done at the destination point based on the sequence number of the packets.
- It is possible for a packet to be destroyed if one of the nodes on its way is crashed momentarily. Thus all its queued packets may be lost.

Packet Switching: Virtual Circuit

- In the virtual circuit approach, a preplanned route is established before any data packets are sent.
- A logical connection is established when
 - a sender send a "call request packet" to the receiver and
 - the receiver send back an acknowledge packet "call accepted packet" to the sender if the receiver agrees on conversational parameters.
- The conversational parameters can be maximum packet sizes, path to be taken, and other variables necessary to establish and maintain the conversation.
- Virtual circuits imply acknowledgements, flow control, and error control, so virtual circuits are reliable.
- That is, they have the capability to inform upper-protocol layers if a transmission problem occurs.

Packet Switching: Virtual Circuit

- In virtual circuit, the route between stations does not mean that this is a dedicated path, as in circuit switching.
- A packet is still buffered at each node and queued for output over a line.
- The difference between virtual circuit and datagram approaches:
 - With virtual circuit, the node does not need to make a routing decision for each packet.
 - It is made only once for all packets using that virtual circuit.

Packet Switching: Virtual Circuit

VC guarantees that

- the packets arrive in the order they sent
- there are no duplicates or omissions.
- there are no errors (with high probability)
regardless of how they are implemented internally.

Advantages of packet switching

Advantages:

- Packet switching is cost effective, because switching devices do not need massive amount of secondary storage.
- Packet switching offers improved delay characteristics, because there are no long messages in the queue (maximum packet size is fixed).
- Packet can be rerouted if there is any problem, such as, busy or disabled links.
- The advantage of packet switching is that many network users can share the same channel at the same time. Packet switching can maximize link efficiency by making optimal use of link bandwidth.

Disadvantages of packet switching

Disadvantages:

- Protocols for packet switching are typically more complex.
- It can add some initial costs in implementation.
- If packet is lost, sender needs to retransmit the data.
- Another disadvantage is that packet-switched systems still can't deliver the same quality as dedicated circuits in applications requiring very little delay - like voice conversations or moving images.