

TRANSMISSION MEDIA

SUBJECT: DATA COMMUNICATION & OPTICAL FIBERS

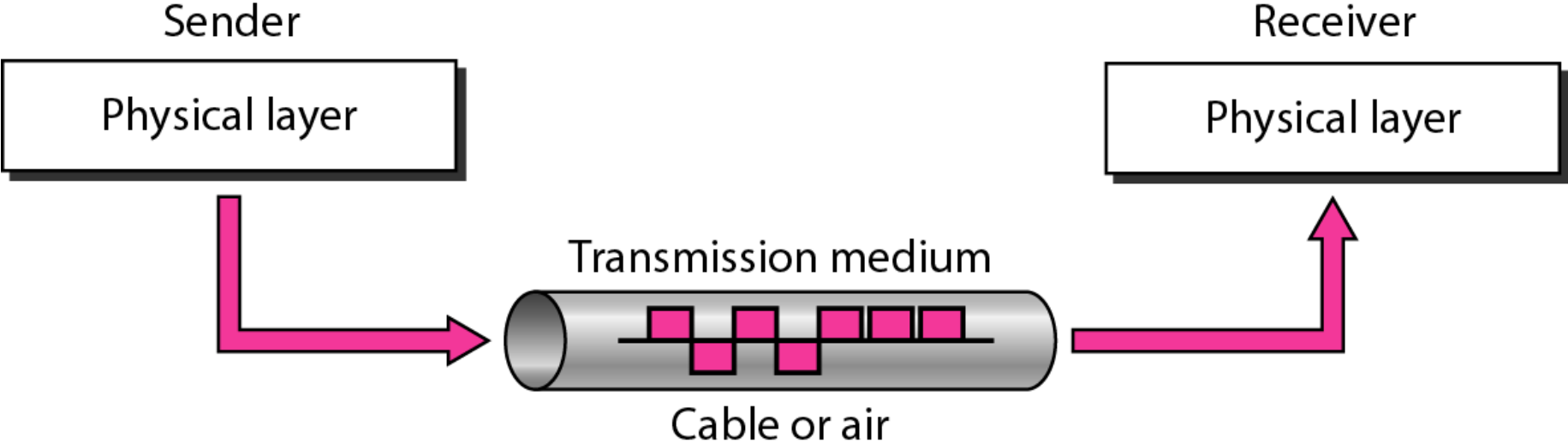
SAVIYA VARGHESE
Dept of COMPUTER APPLICATION
2020-21

TRANSMISSION MEDIA

- ⦿ A transmission medium can be broadly defined as anything that can carry information from a source to a destination.
- ⦿ The transmission medium is usually free space, metallic cable, or fiber-optic cable.

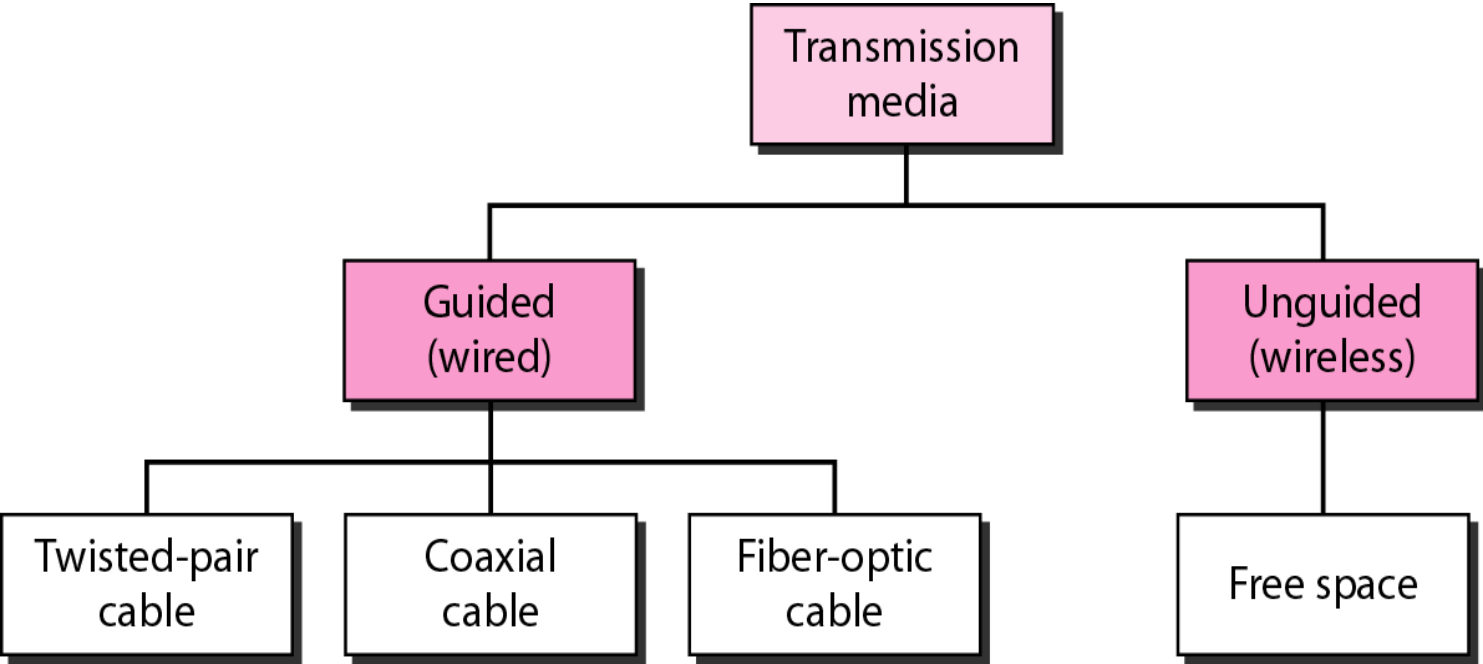


Figure 7.1 *Transmission medium and physical layer*



- ◉ In telecommunications, transmission media can be divided into two broad categories: guided and unguided.
- ◉ Guided media include twisted-pair cable, coaxial cable, and fiber-optic cable. Unguided medium is free space.

Figure 7.2 *Classes of transmission media*



7-1 GUIDED MEDIA

Guided media, which are those that provide a conduit from one device to another, include twisted-pair cable, coaxial cable, and fiber-optic cable.

Twisted-Pair Cable

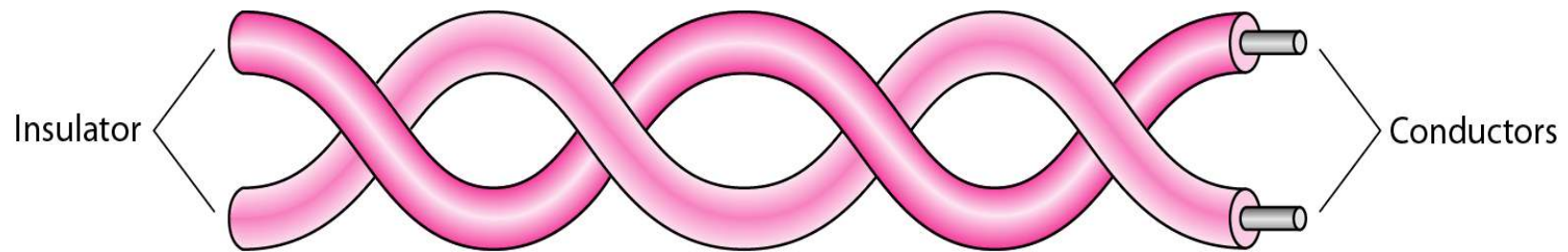
Coaxial Cable

Fiber-Optic Cable

TWISTED PAIR CABLE

- ◉ A twisted pair consists of two conductors (normally copper), each with its own plastic insulation, twisted together.
- ◉ One of the wires is used to carry signals to the receiver, and the other is used only as a ground reference. The receiver uses the difference between the two.
- ◉ In addition to the signal sent by the sender on one of the wires, interference (noise) and crosstalk may affect both wires and create unwanted signals.
- ◉ The twisting of the individual pairs minimizes electromagnetic interference between the pairs.

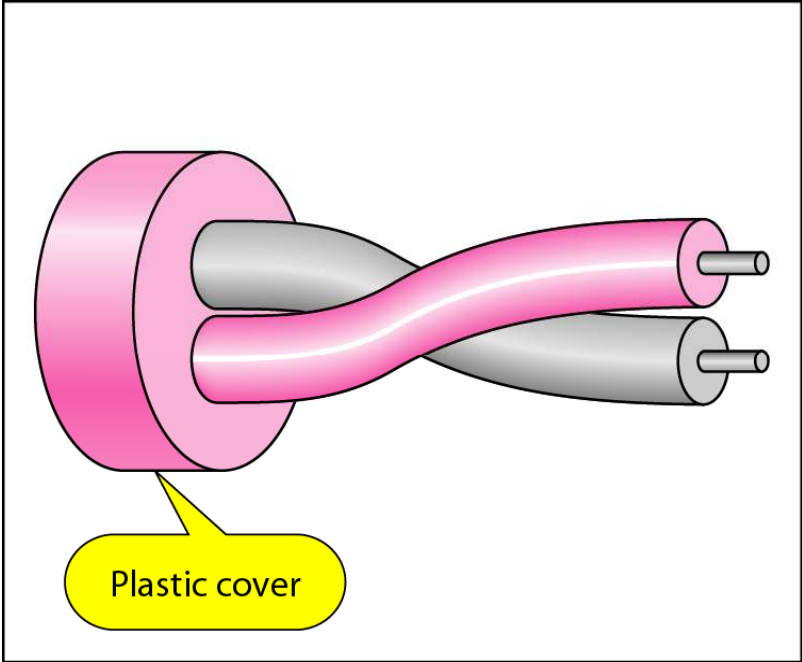
Figure 7.3 *Twisted-pair cable*



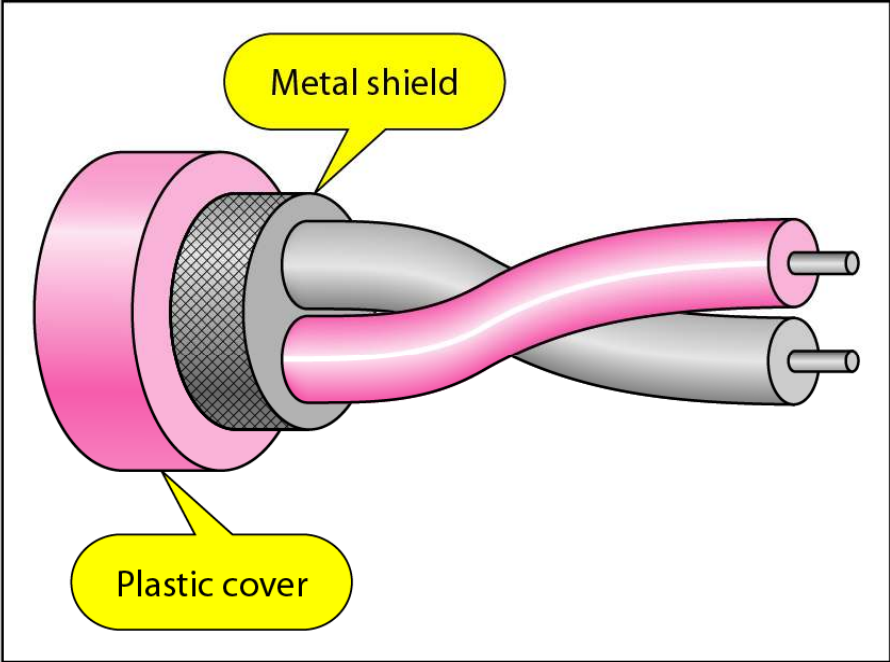
UNSHIELDED & SHIELDED TWISTED PAIR

- ◉ The most common twisted-pair cable used in communications is referred to as unshielded twisted-pair (UTP).
- ◉ IBM has also produced a version of twisted-pair cable for its use called shielded twisted-pair (STP).
- ◉ STP cable has a metal foil or braided mesh covering that encases each pair of insulated conductors. Although metal casing improves the quality of cable by preventing the penetration of noise or crosstalk, it is bulkier and more expensive.

Figure 7.4 *UTP and STP cables*



a. UTP



b. STP

- *Categories*

The Electronic Industries Association (EIA) has developed standards to classify unshielded twisted-pair cable into seven categories. Categories are determined by cable quality, with 1 as the lowest and 7 as the highest. Each EIA category is suitable for specific uses.

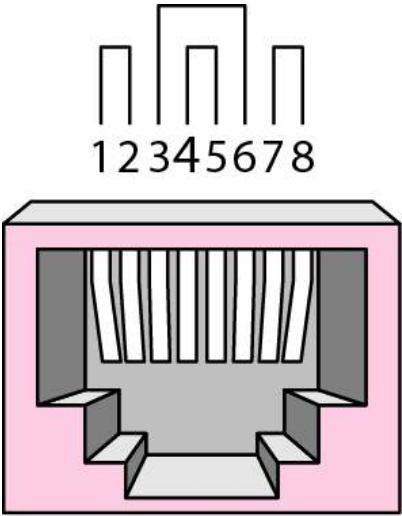
- *Connectors*

The most common UTP connector is RJ45 (RJ stands for registered jack), as shown in Figure 7.5. The RJ45 is a keyed connector, meaning the connector can be inserted in only one way.

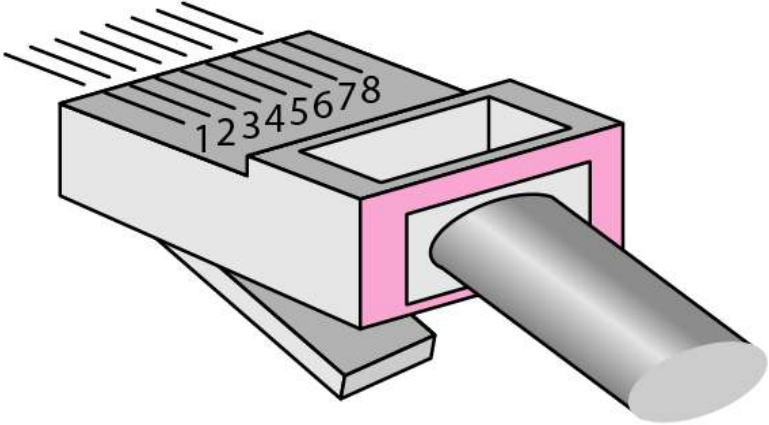
- *Performance*

One way to measure the performance of twisted-pair cable is to compare attenuation versus frequency and distance. A twisted-pair cable can pass a wide range of frequencies.

Figure 7.5 *UTP connector*



RJ-45 Female



RJ-45 Male



APPLICATIONS

- ◉ Twisted-pair cables are used in telephone lines to provide voice and data channels.
- ◉ The local loop-the line that connects subscribers to the central telephone office---commonly consists of unshielded twisted-pair cables.
- ◉ The DSL lines that are used by the telephone companies to provide high-data-rate connections also use the high-bandwidth capability of unshielded twisted-pair cables.
- ◉ Local-area networks, such as 10 Base-T and 100 Base-T, also use twisted-pair cables.