

Memory Organization

Subject: Computer Organization & Architecture

Saviya Varghese

Dept of BCA

2020-21

MEMORY HIERARCHY

- The memory unit is an essential component in any digital computer since it is needed for storing programs and data.
- A very small computer with a limited application may be able to fulfill its intended task without the need of additional storage capacity.
- Most general-purpose computers would run more efficiently if they were equipped with additional storage beyond the capacity of the main memory.
- There is just not enough space in one memory unit to accommodate all the programs used in a typical computer.

- 
- Moreover, most computer users accumulate and continue to accumulate large amounts of data-processing software.
 - Not all accumulated information is needed by the processor at the same time.
 - Therefore, it is more economical to use low-cost storage devices to serve as a backup for storing the information that is not currently used by the CPU.

- 
- The memory unit that communicates directly with the CPU is called the main memory.
 - Devices that provide backup storage are called auxiliary memory.
 - The most common auxiliary memory devices used in computer systems are magnetic disks and tapes.
 - They are used for storing system programs, large data files, and other backup information.
 - Only programs and data currently needed by the processor reside in main memory.
 - All other information is stored in auxiliary memory and transferred to main memory when needed.

- 
- The total memory capacity of a computer can be visualized as being a hierarchy of components.
 - The memory hierarchy system consists of all storage devices employed in a computer system from the slow but high-capacity auxiliary memory to a relatively faster main memory, to an even smaller and faster cache memory accessible to the high-speed processing logic.

MEMORY HIERARCHY

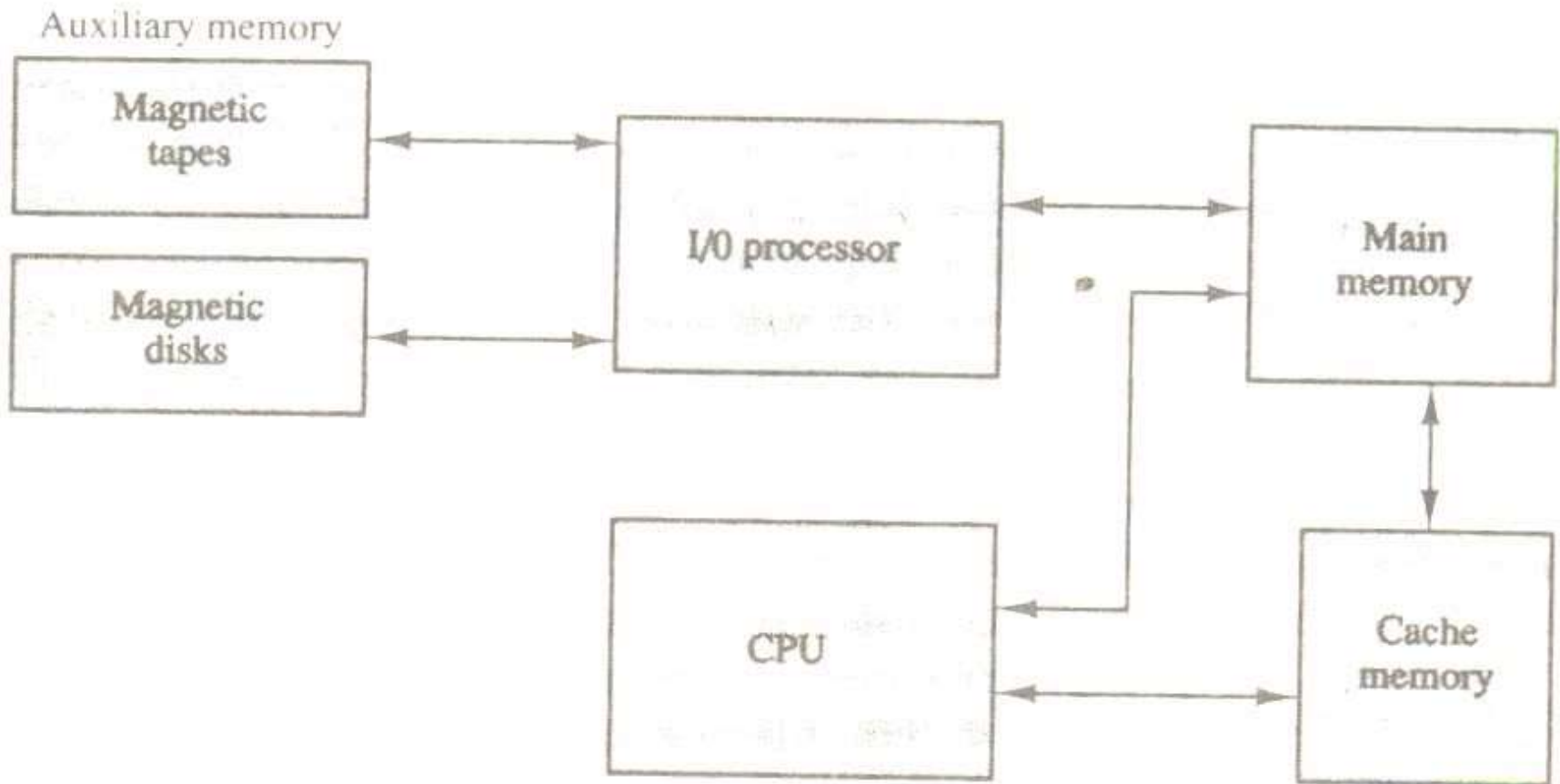

- The above Figure illustrates the components in a typical memory hierarchy.
- At the bottom of the hierarchy are the relatively slow magnetic tapes used to store removable files.
- Next are the magnetic disks used as backup storage.
- The main memory occupies a central position by being able to communicate directly with the CPU and with auxiliary memory devices through an I/O processor.
- When programs not residing in main memory are needed by the CPU, they are brought in from auxiliary memory.
- Programs not currently needed in main memory are transferred into auxiliary memory to provide space for currently used programs and data.

- A special very-high speed memory called a cache is sometimes used to increase the speed of processing by making current programs and data available to the CPU at a rapid rate.
- The cache memory is employed in computer systems to compensate for the speed differential between main memory access time and processor logic.
- CPU logic is usually faster than main memory access time, with the result that processing speed is limited primarily by the speed of main memory.
- A technique used to compensate for the mismatch in operating speeds is to employ in extremely fast, small cache between the CPU and main memory whose access time is close to processor logic clock cycle time.

- The cache is used for storing segments of programs currently being executed in the CPU and temporary data frequently needed in the present calculations by making programs and data available at a rapid rate, it is possible to increase the performance rate of the computer.
- While the I/O processor manages data transfers between auxiliary memory and main memory, the cache organization is concerned with the transfer of information between main memory and CPU. Thus each is involved with a different level in the memory hierarchy system.

- The reason for having two or three levels of memory hierarchy is economics.
- As the storage capacity of the memory increases, the cost per bit for storing binary information decreases and the access time of the memory becomes longer.
- The auxiliary memory has a large storage capacity, is relatively inexpensive, but has low access speed compared to main memory.
- The cache memory is very small, relatively expensive, and has very high access speed.
- Thus as the memory access speed increases, so does its relative cost.
- The overall goal of using a memory hierarchy is to obtain the highest-possible average access speed while minimizing the total cost of the entire memory system.

- Auxiliary and cache memories are used for different purposes.
- The cache holds those parts of the program and data that are most heavily used, while the auxiliary memory holds those parts that are not presently used by the CPU.
- Moreover, the CPU has direct access to both cache and main memory but not to auxiliary memory.
- The transfer from auxiliary to main memory is usually done by means of direct memory access of large blocks of data.
- The typical access time ratio between cache and main memory is about 1 to 7.

EXAMPLE

- A typical cache memory may have an access time of 100ns, while main memory access time may be 700ns.
- Auxiliary memory average access time is usually 1000 times that of main memory.
- Block size in auxiliary memory typically ranges from 256 to 2048 words, while cache block size is typically from 1 to 16 words

- Many operating systems are designed to enable the CPU to process a number of independent programs concurrently.
- This concept, called multiprogramming, refers to the existence of two or more programs in different parts of the memory hierarchy at the same time.
- In this way it is possible to keep all parts of the computer busy by working with several programs in sequence.
- For example, suppose that a program is being executed in the CPU and an I/O transfer is required.
- The CPU initiates the I/O processor to start executing the transfer. This leaves the CPU free to execute another program.
- In a multiprogramming system, when one program is waiting for input or output transfer, there is another program ready to utilize the CPU.

- 
- With multiprogramming the need arises for running partial programs, for varying the amount of main memory in use by a given program, and for moving programs around the memory hierarchy.
 - Programs are sometimes too long to be accommodated in the total space available in main memory.
 - Moreover, a computer system uses many programs and all the programs cannot reside in main memory at all times

- A program with its data normally resides in auxiliary memory.
- When the program or a segment of the program is to be executed, it is transferred to main memory to be executed by the CPU.
- Thus one may think of auxiliary memory as containing the totality of information stored in a computer system.
- It is the task of the operating system to maintain in main memory a portion of this information that is currently active.
- The part of the computer system that supervises the flow of information between auxiliary memory and main memory is called the memory management system.