

Computer Organization and Architecture



MAGI THOMAS
DEPARTMENT OF COMPUTER APPLICATION

Transmission of Digital Data

Interfaces and Modems

- Digital Data Transmission
- DTE-DCE Interface
- Other Interface Standards
- Modems

Data transmission

```
graph TD; A[Data transmission] --> B[Parallel]; A --> C[Serial]; C --> D[Synchronous]; C --> E[Asynchronous];
```

Parallel

Serial

Synchronous

Asynchronous

Parallel Transmission

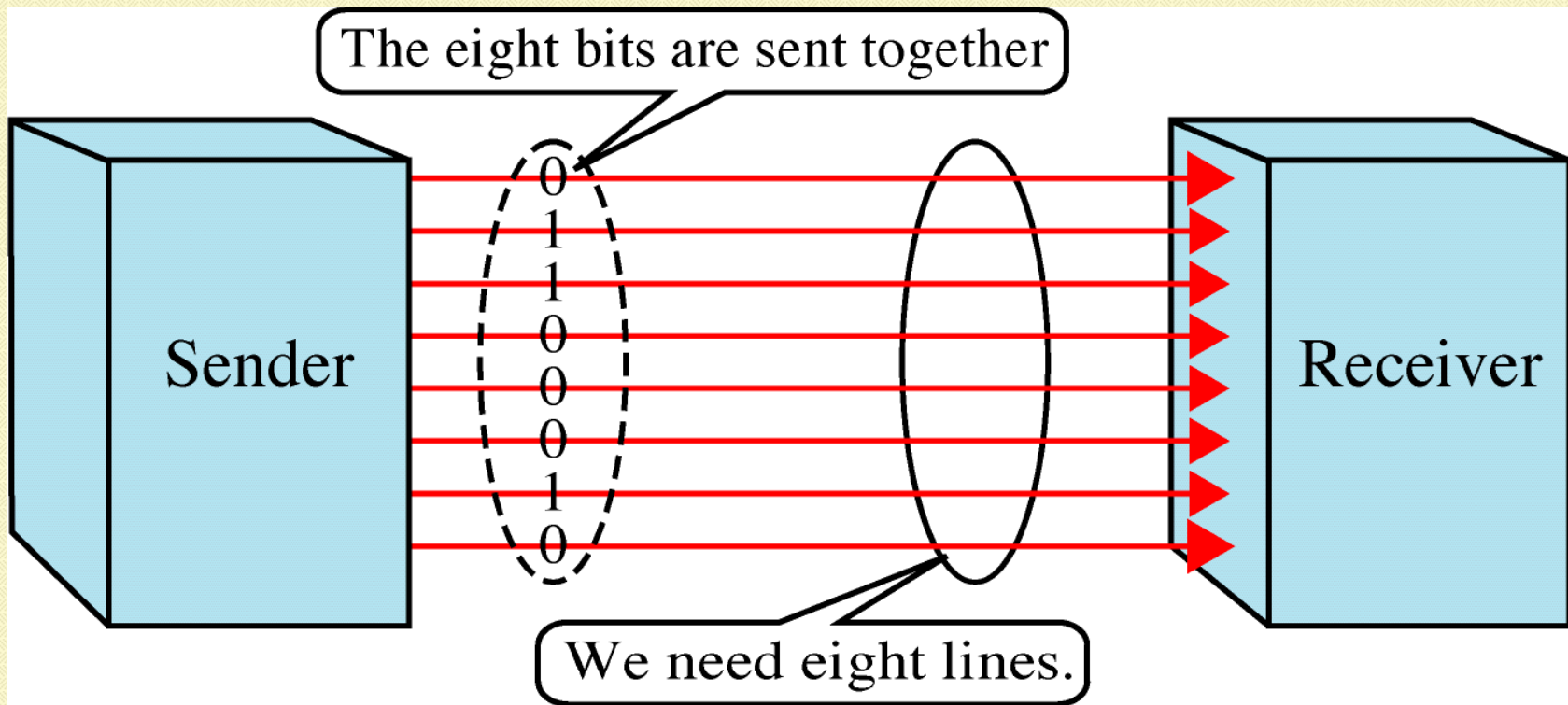

Serial Transmission

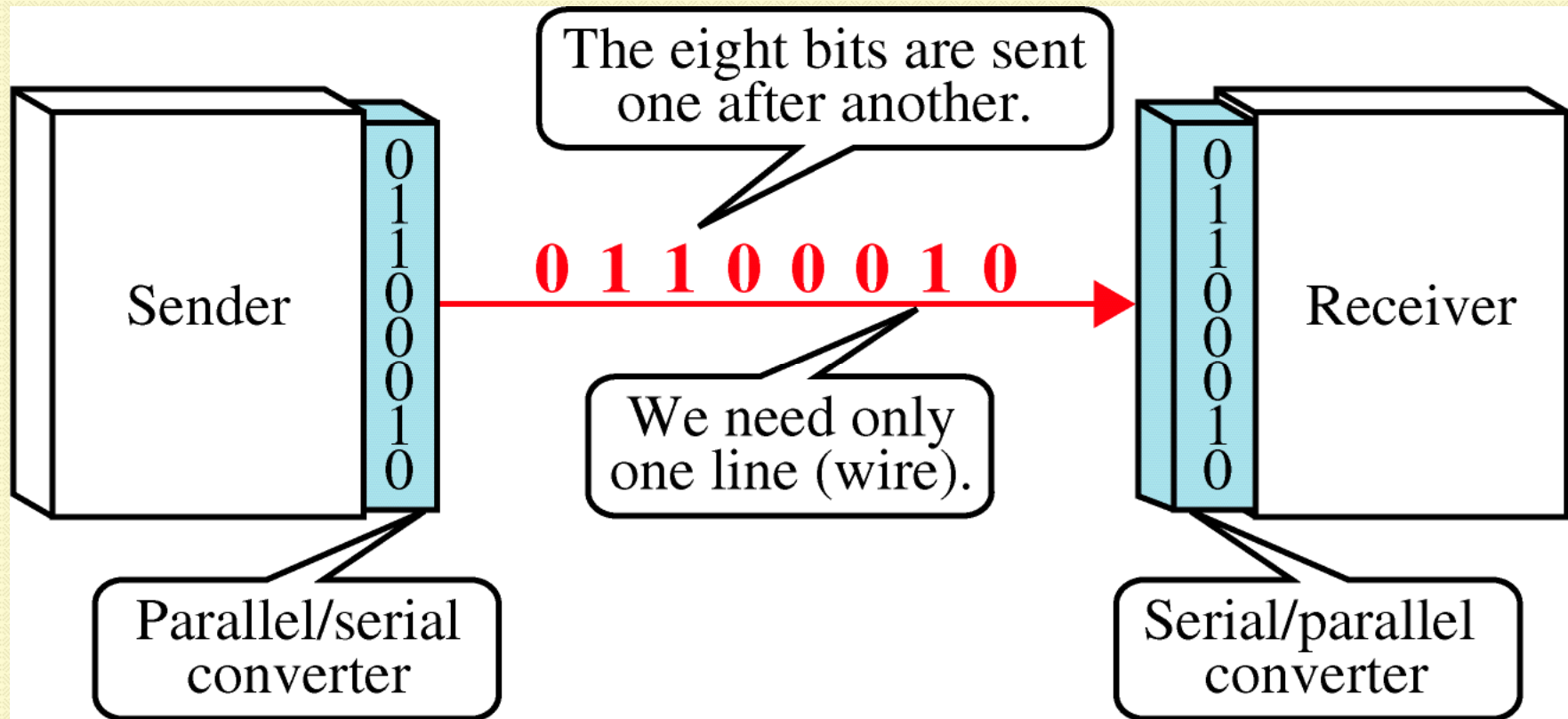

Asynchronous Transmission

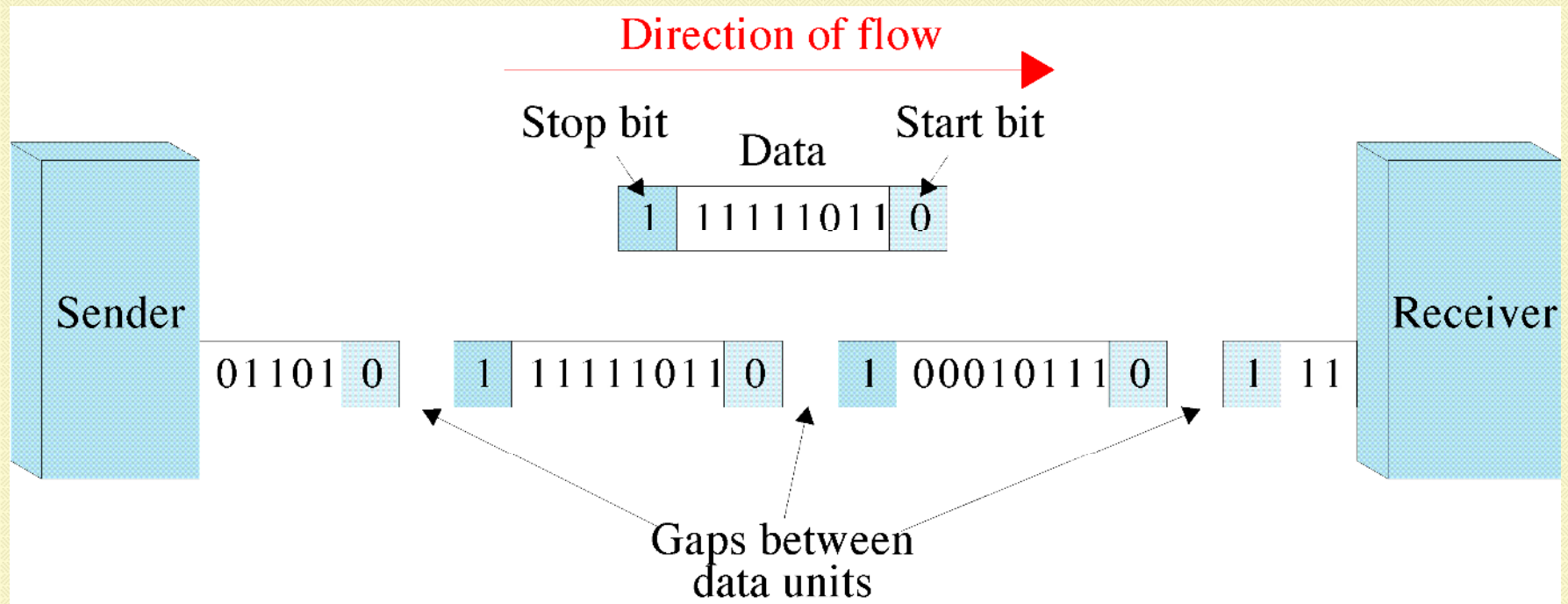

Synchronous Transmission

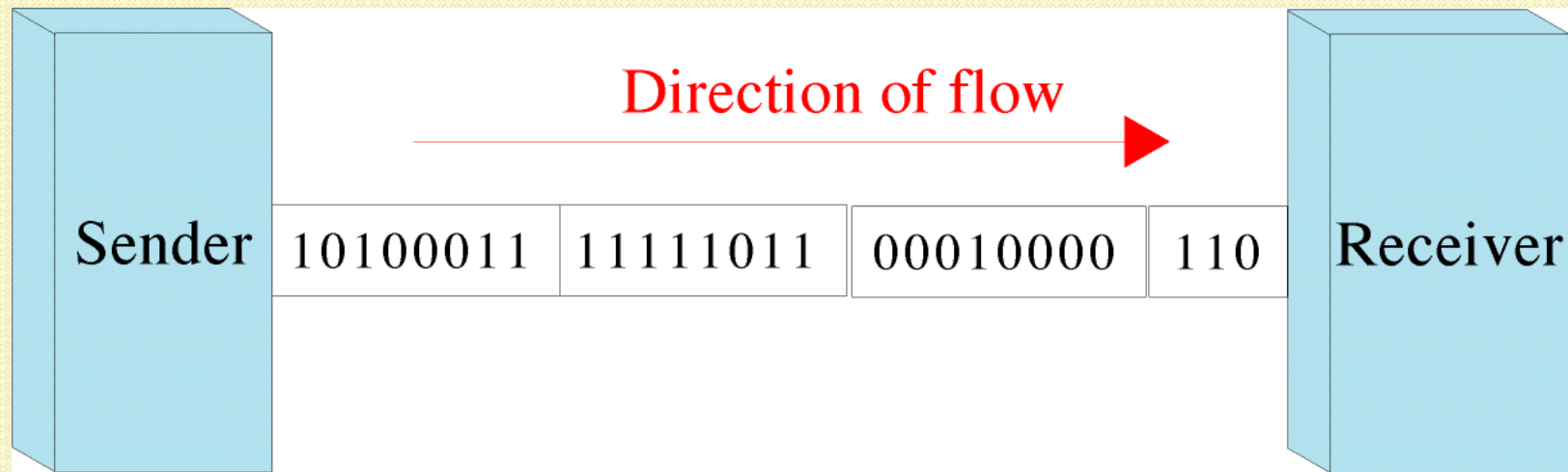

DTEs and DCEs

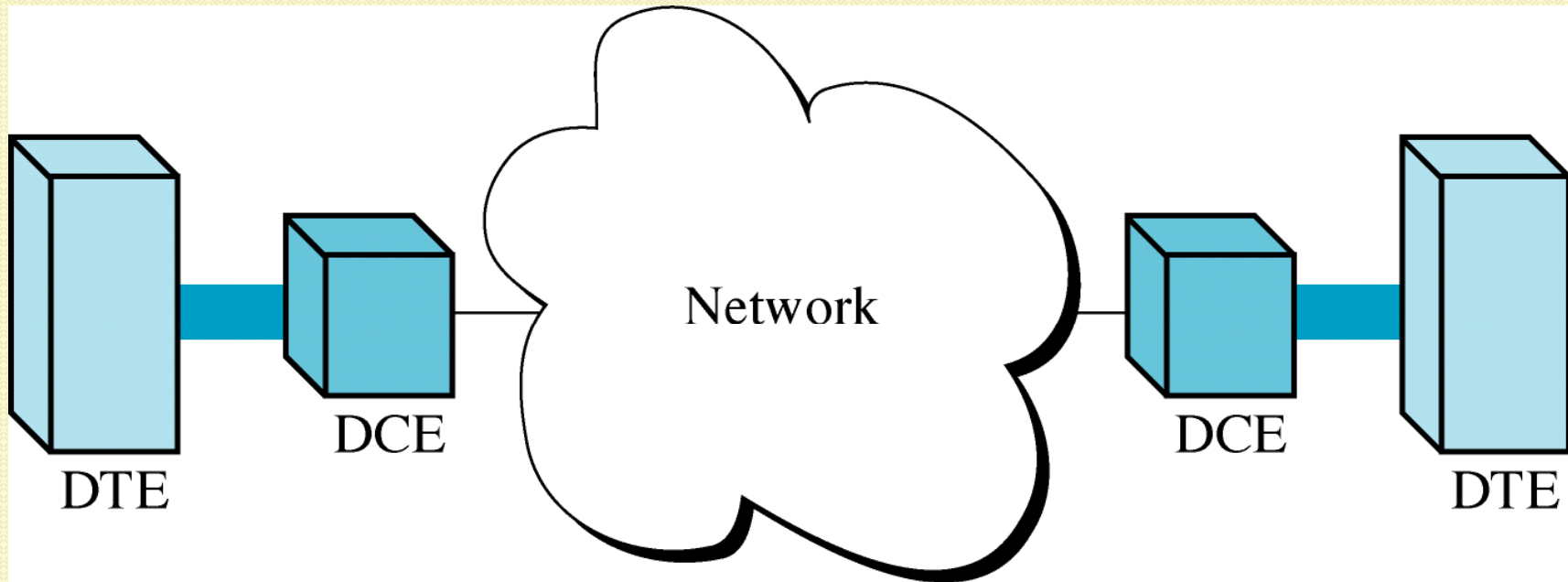

DTE-DCE interface

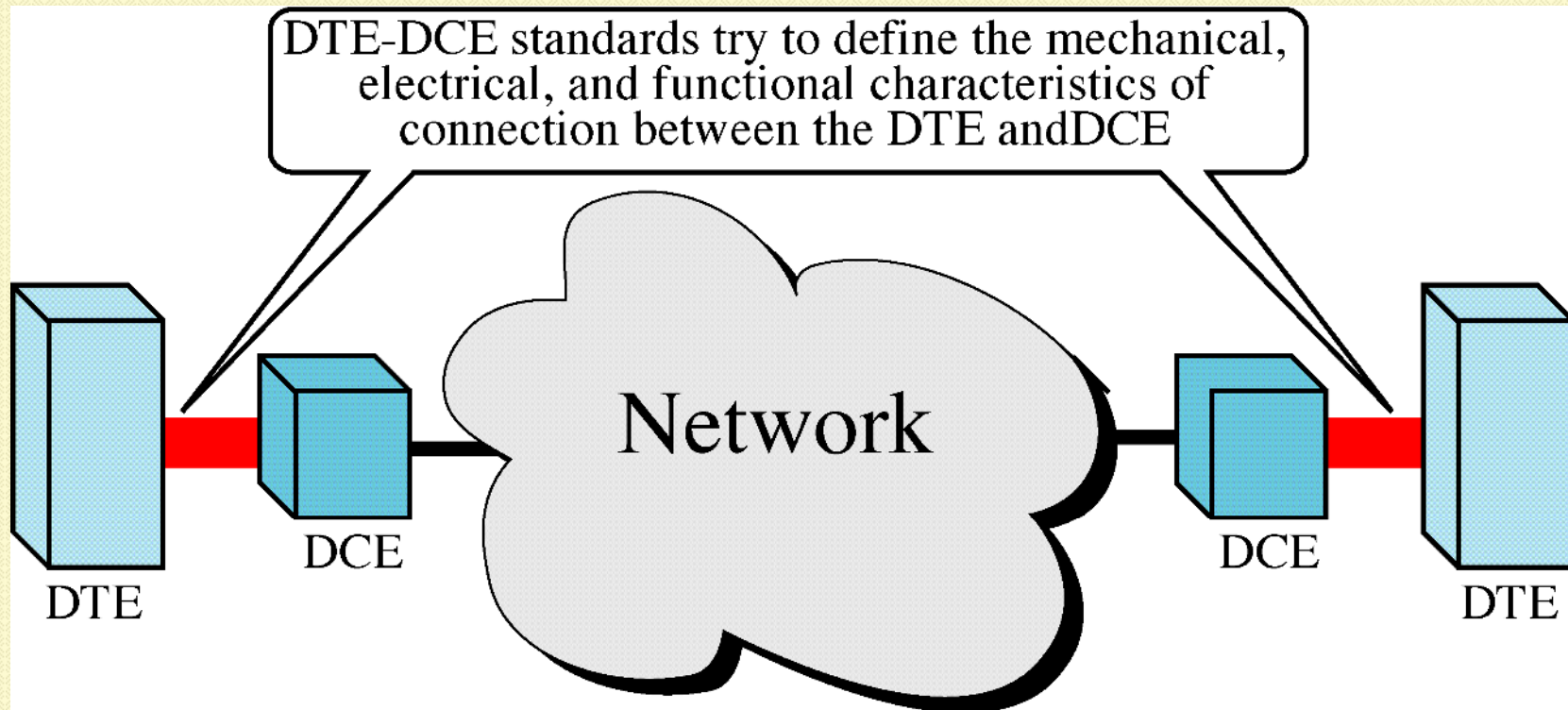

Sending Data

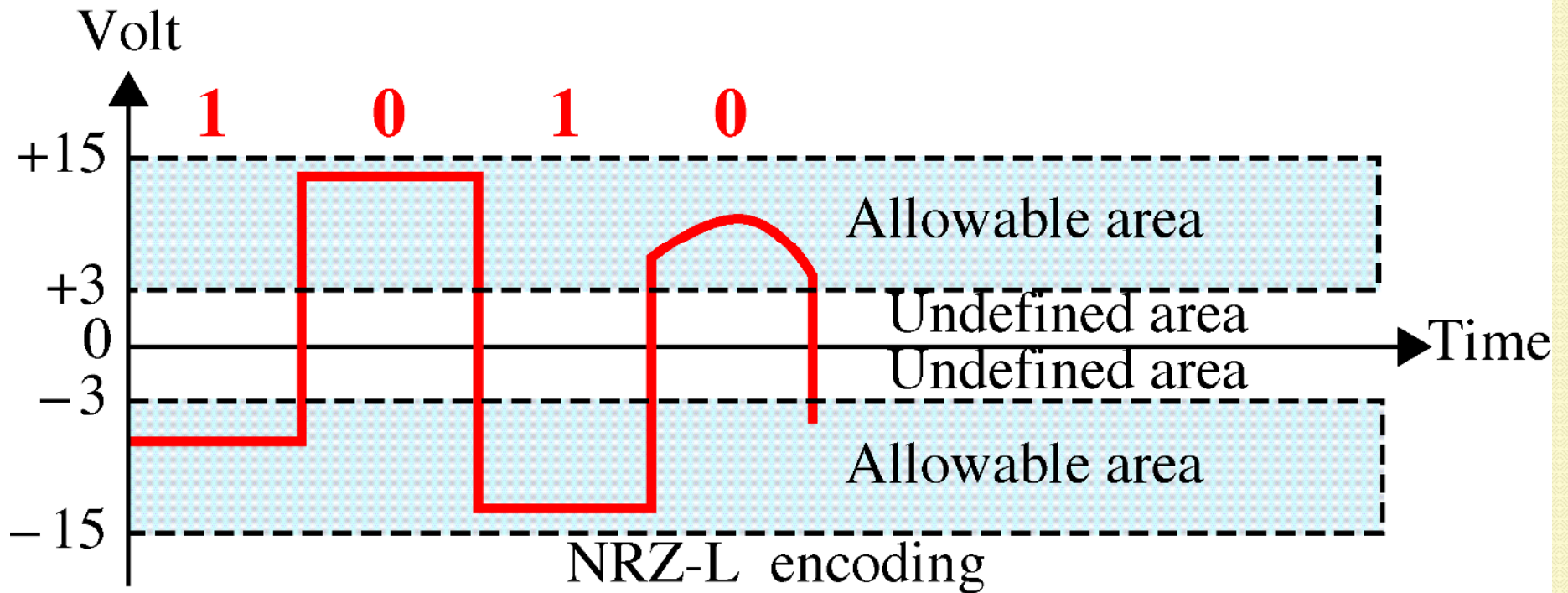

Control

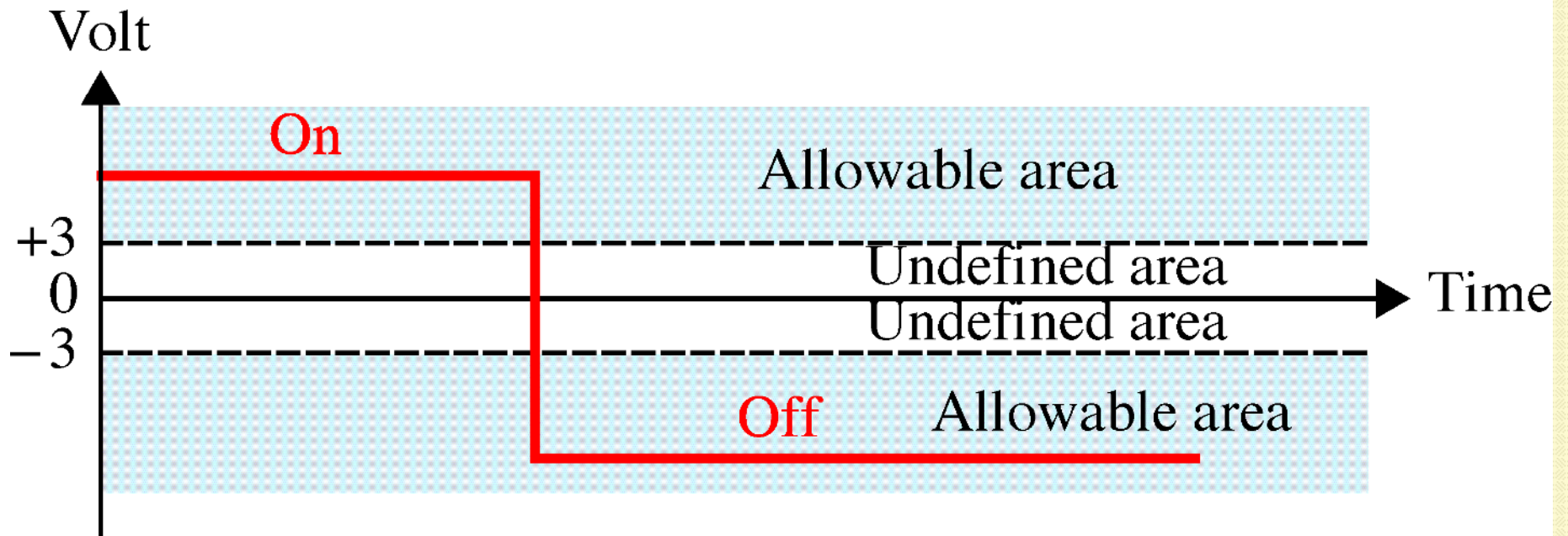

EIA-232

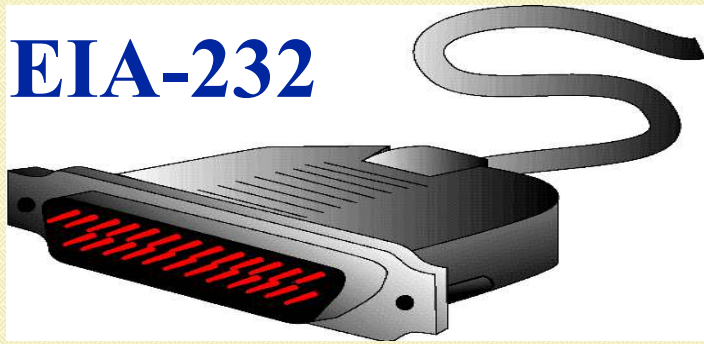

Data Pins

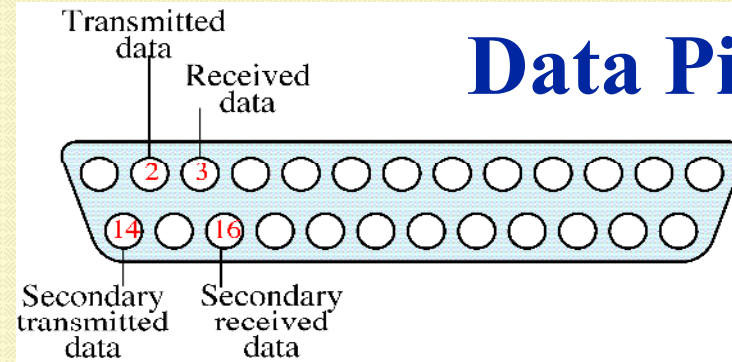

Control Pins

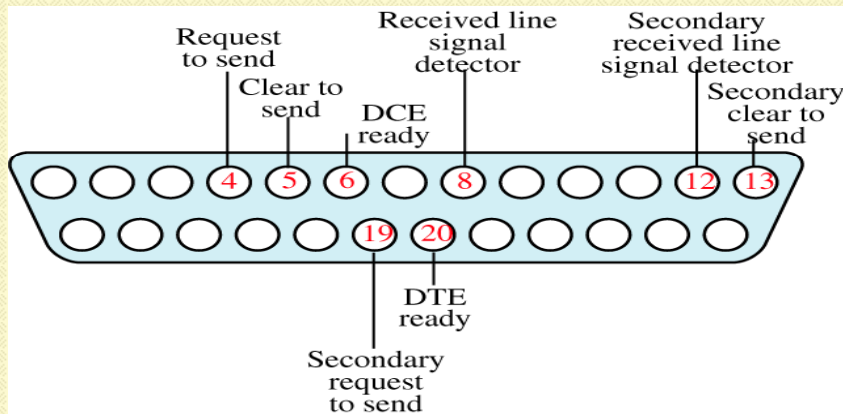

Timing Pins

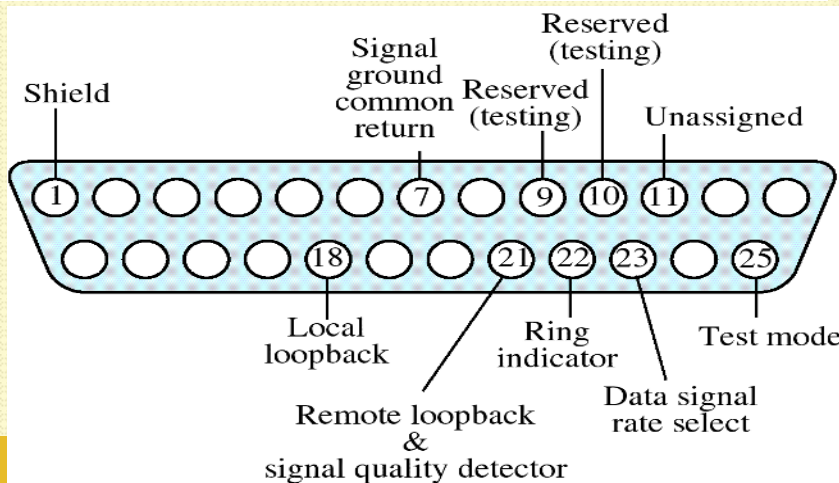
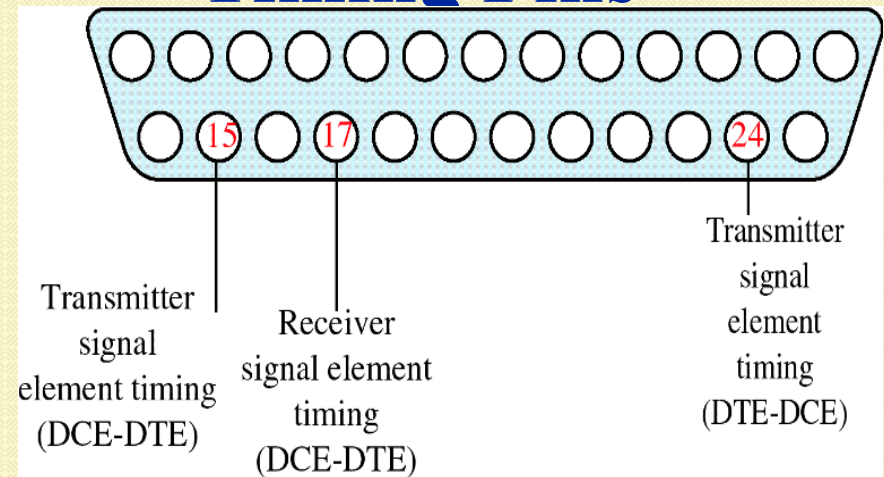

Other Pins

Synchronous Full-Duplex Transmission

1 Shield
5 Clear to send
7 Signal ground
4 Request to send
6 DCE ready
20 DTE ready
8 Received line signal detector

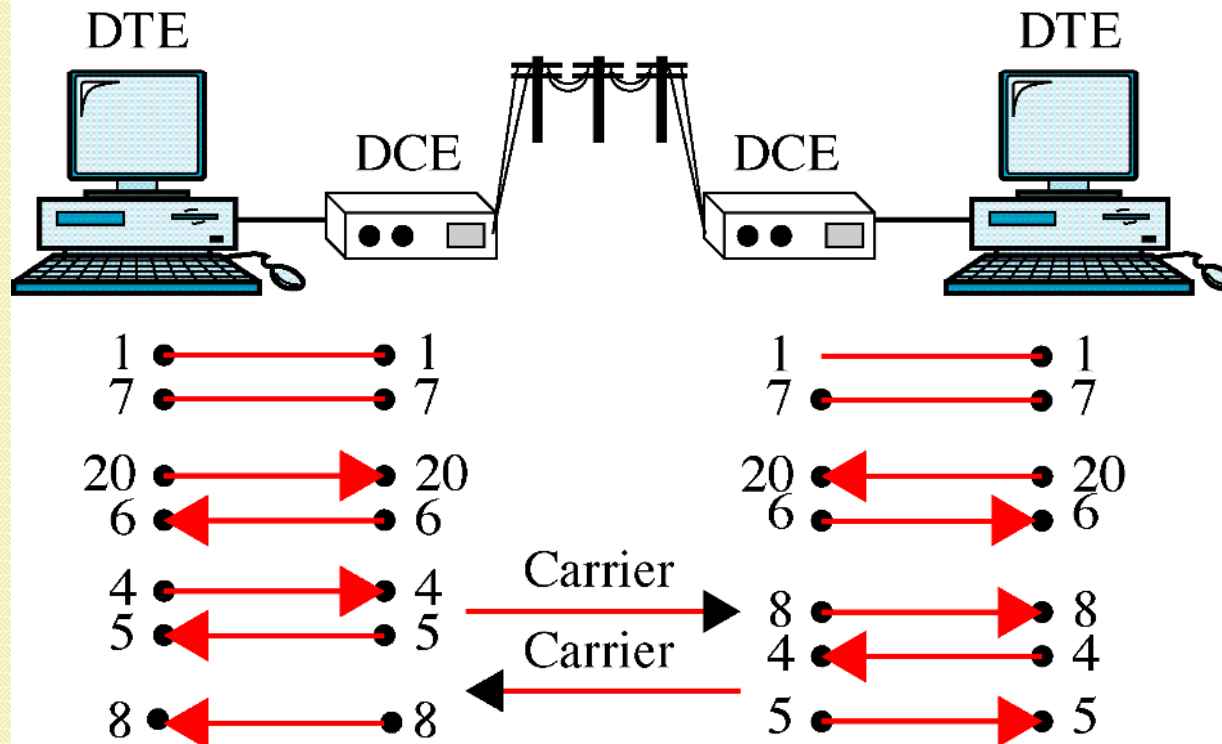

Synchronous Full-Duplex Transmission

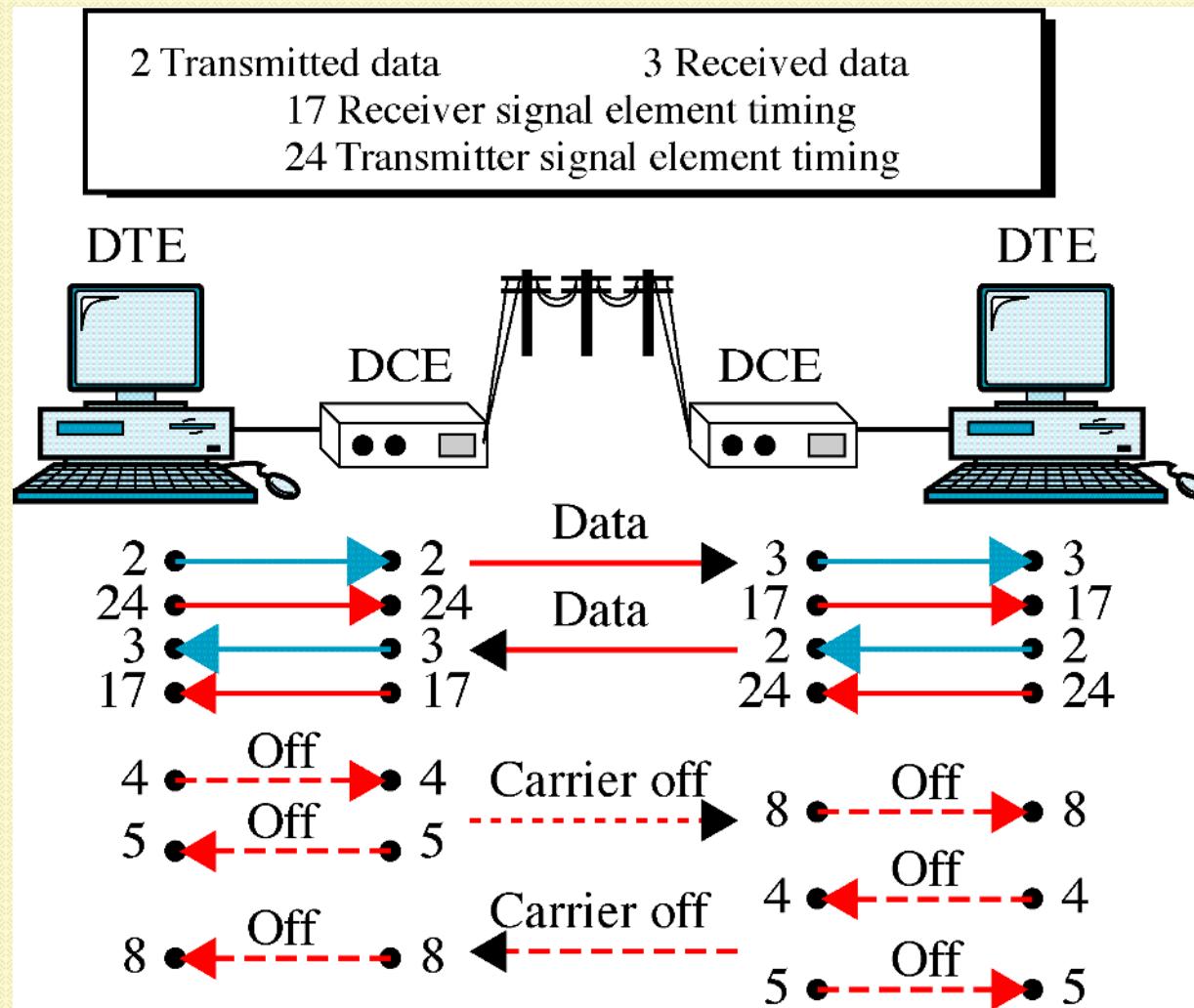

Pin Connection With and Without DCEs

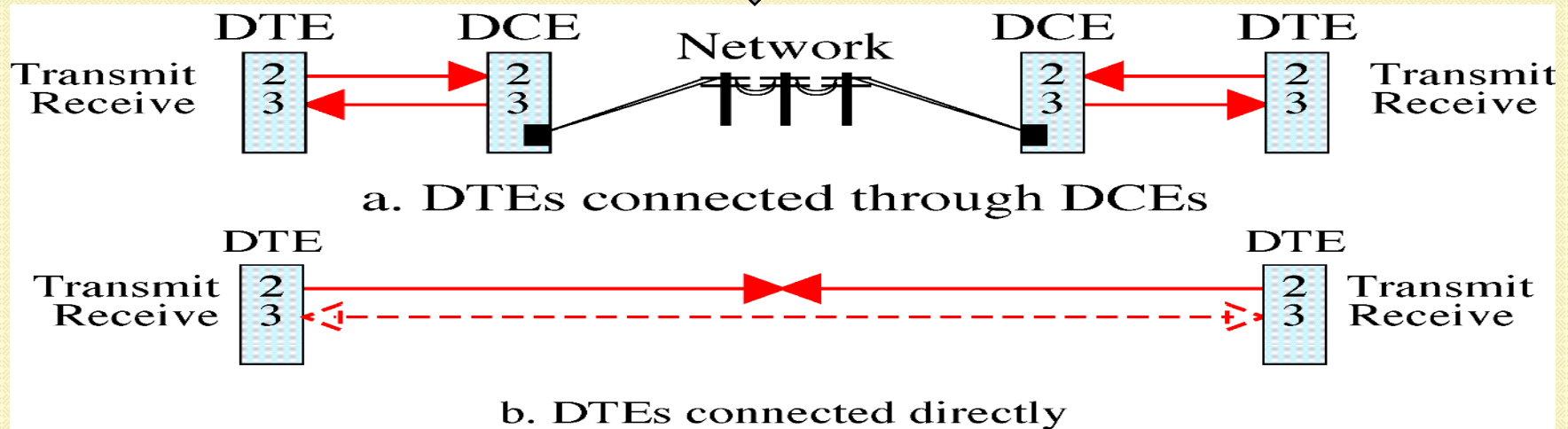
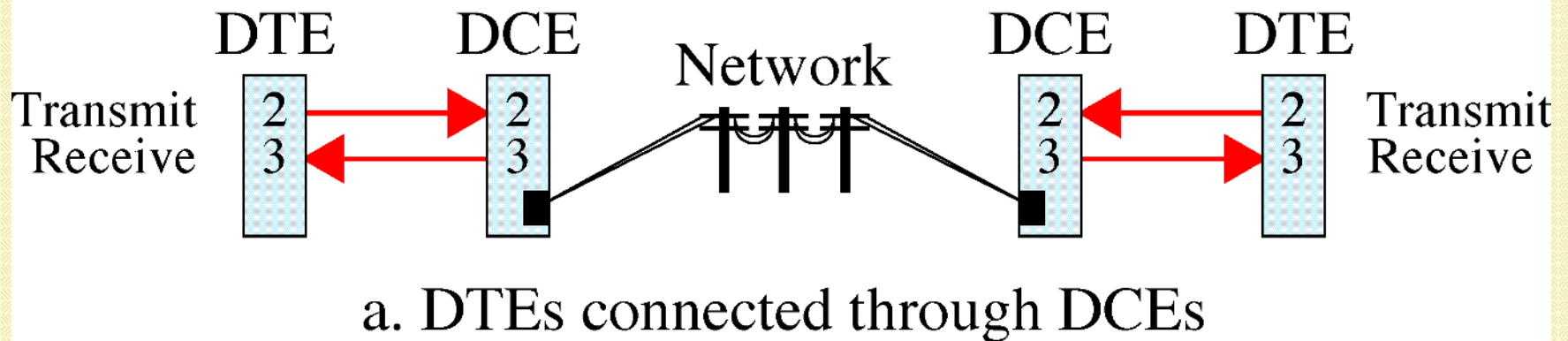

Null Modem

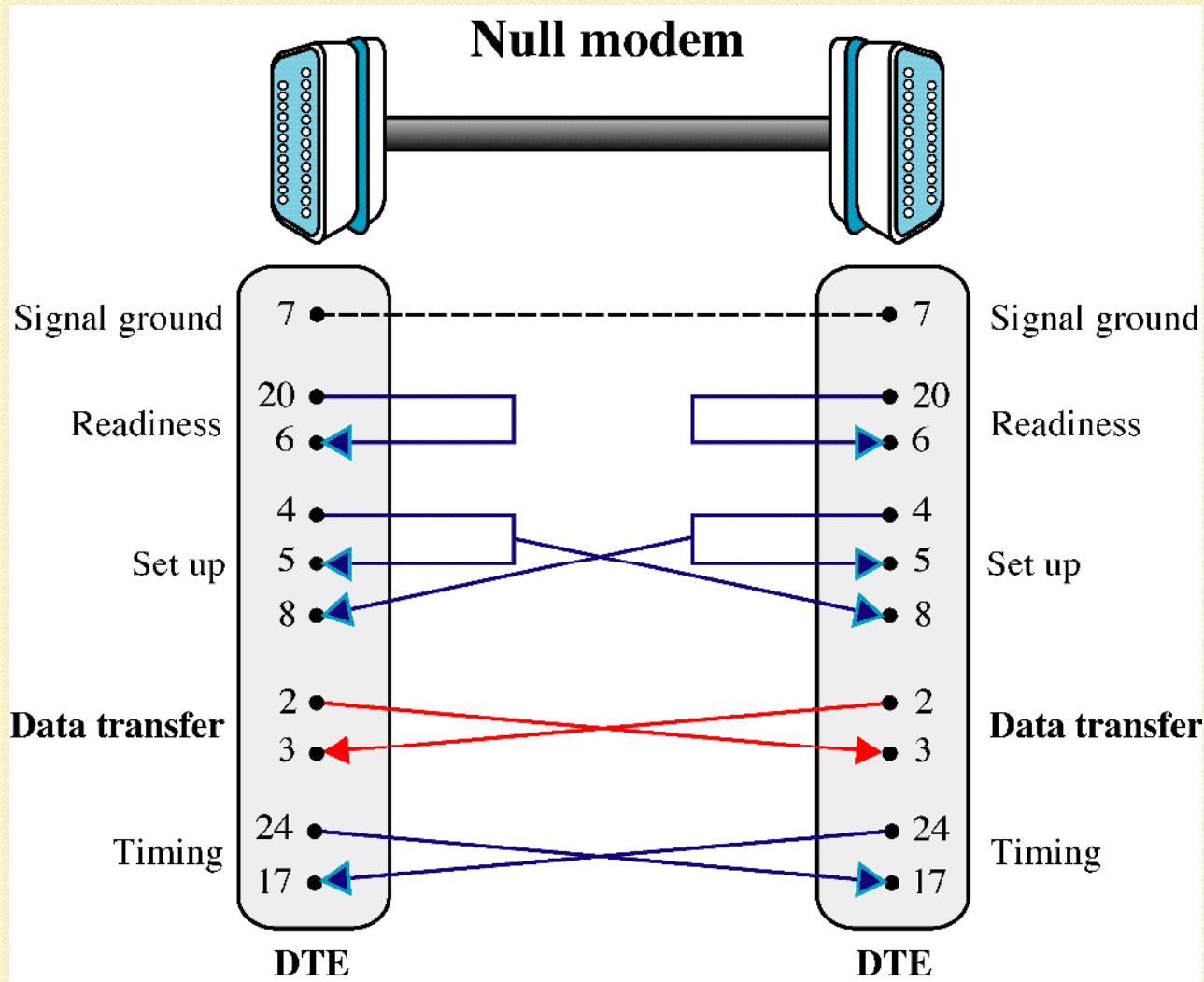



*Thank
you*